

**DISASSEMBLY & ASSEMBLY GATE VALVE  
WITH FLOATING BACKSEAT (½" - 1")**

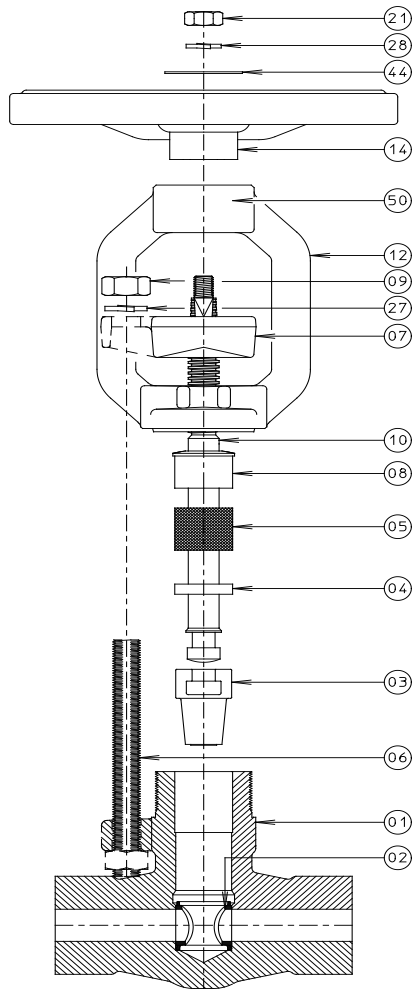

1. Caution, before any attempt is made to disassemble, verify that the valve is isolated from system pressure and secured against accidental pressurisation.
2. Unscrew the nuts (09) from the gland bolts (06) and remove the gland bolts.
3. Open the valve completely.
4. Loosen the yoke (12) by applying a force in a counterclockwise direction and unscrew it partly from the body:
  - 7 revolutions for 3/8"-1/2" valves
  - 10 revolutions for 3/4"-1" valves
5. Turn the hand wheel (14) counter clockwise, past the fully open position to force the packing (05) and the floating backseat (04) out of the stuffing box.
6. Unscrew the yoke and jack it together with the remaining parts out of the valve body (01).
7. Remove the nut (21) which secures the hand wheel and rotate the hand wheel clockwise to unscrew the stem (10) from the yoke sleeve (50) until the hand wheel disengages from the stem.
8. Continue unscrewing the stem by gripping it below the yoke.
9. Remove the gland flange (07), the gland (08), the packing and the floating backseat from the stem by holding the stem vertically on a bench with the threaded end down and pressing it down on the floating backseat.

INSPECTION FOR RE-ASSEMBLY

1. Thoroughly wipe all parts with solvent and a clean cloth.
2. Examine the following parts for pitting or scratches:
  - A. SEAT (02) - Sealing surface
  - B. STEM - Packing area
  - C. WEDGE (03) - Sealing surface
3. Grease all threaded parts with molykote HCS, or equivalent.
4. Insert the stem/wedge-assembly into the valve body.
5. Insert the floating backseat (with radius down) into the valve body.
6. Insert the packing into the valve body (with markings down).
7. Place the gland over the stem.
8. Put the yoke together with the gland flange over the stem.
9. Screw the yoke on the valve body, while turning the stem counterclockwise.
10. Fix the gland flange with the stud bolts.
11. Fix the hand wheel and nameplate (44) to the stem with the nut and washer (28).
12. Tighten the nuts of the stud bolts. (to compress the packing).
13. Loosen the nuts of the stud bolts.
14. Then carefully tighten the nuts of the stud bolts again.
15. Pressurise the system and check the gland packing.
16. In case of leaking, tighten the nuts of the gland bolts carefully until the leaking stops.

**DISASSEMBLY & ASSEMBLY GATE VALVE  
WITH FLOATING BACKSEAT (1¼" - 2")**

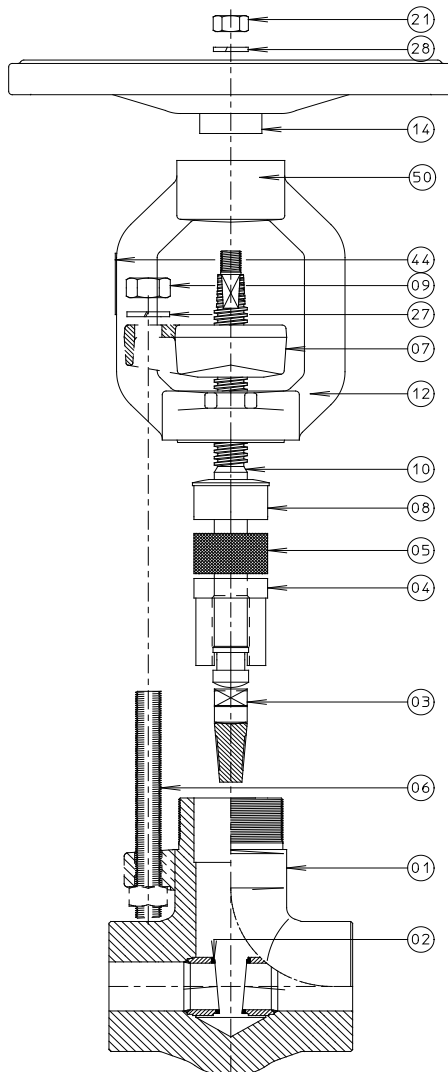

1. Caution, before any attempt is made to disassemble, verify that the valve is isolated from system pressure and secured against accidental pressurisation.
2. Unscrew the nuts (09) from the gland bolts (06) and remove the gland bolts.
3. Open the valve completely.
4. Loosen the yoke (12) by applying a force in a counterclockwise direction and unscrew it partly from the body (01): - 17 revolutions.
5. Turn the hand wheel (14) counter clockwise, past the fully open position to force the packing (05) and the floating backseat (04) out of the stuffing box.
6. Unscrew the yoke and jack it together with the remaining parts out of the valve body. Caution: be careful with wedge (03)!
7. Remove the nut (21) which secures the hand wheel and rotate the hand wheel clockwise to unscrew the stem (10) from the yoke sleeve (50) until the hand wheel disengages from the stem.
8. Continue unscrewing the stem by gripping it below the yoke.
9. Remove the gland flange (07), the gland (08), the packing and the floating backseat from the stem by holding the stem vertically on a bench with the threaded end down and pressing it down on the floating backseat.

INSPECTION FOR RE-ASSEMBLY

1. Thoroughly wipe all parts with solvent and a clean cloth.
2. Examine the following parts for pitting or scratches:
  - A. SEAT (02) - Sealing surface
  - B. STEM - Packing area
  - C. WEDGE - Sealing surface
3. Grease all threaded parts with molykote HCS, or equivalent.
4. Place the wedge on the stem and place the floating backseat over the stem and the wedge.
5. Insert the packing into the valve body (with markings down).
6. Place the gland over the stem.
7. Put the yoke together with the gland flange over the stem.
8. Screw the yoke on the valve body, while turning the stem counterclockwise.
9. Fix the gland flange with the stud bolts.
10. Fix the hand wheel to the stem with the nut and washer (28).
11. Tighten the nuts of the stud bolts. (to compress the packing).
12. Loosen the nuts of the stud bolts.
13. Then carefully tighten the nuts of the stud bolts again.
14. Pressurise the system and check the gland packing.
15. In case of leaking, tighten the nuts of the gland bolts carefully until the leaking stops.

**DISASSEMBLY & ASSEMBLY PARALLEL SLIDE GATE VALVE**  
3" - 4" 1500-2500 LBS.

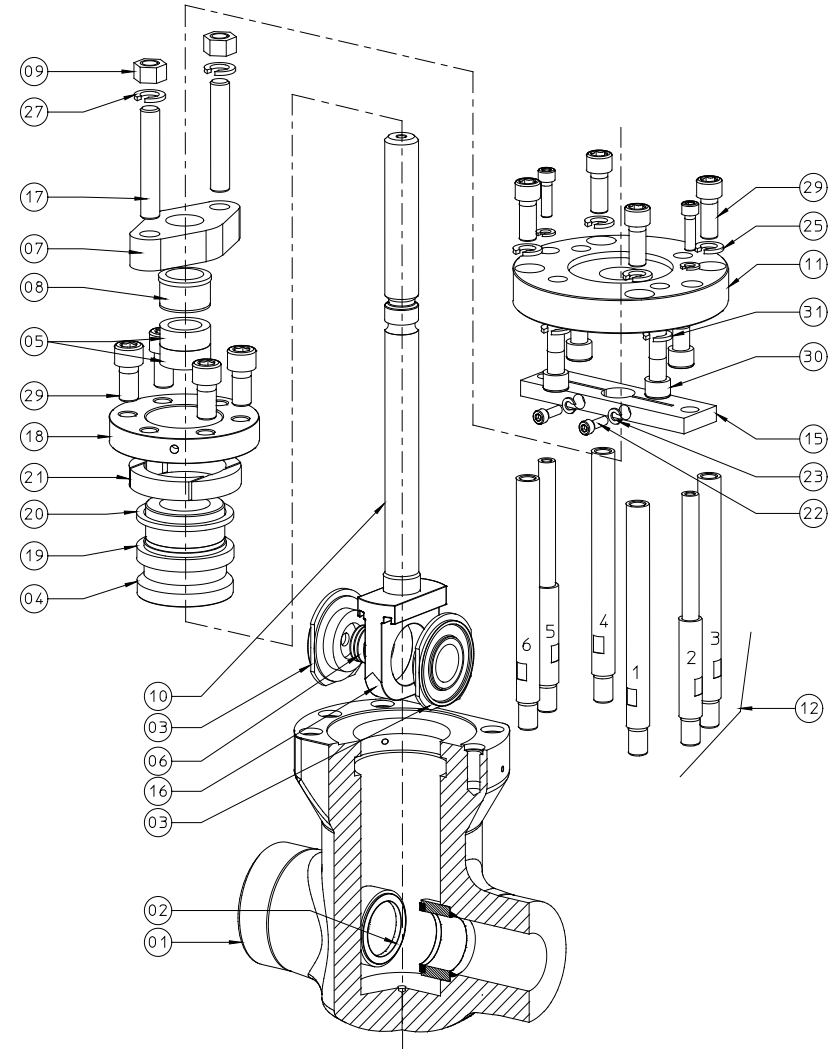
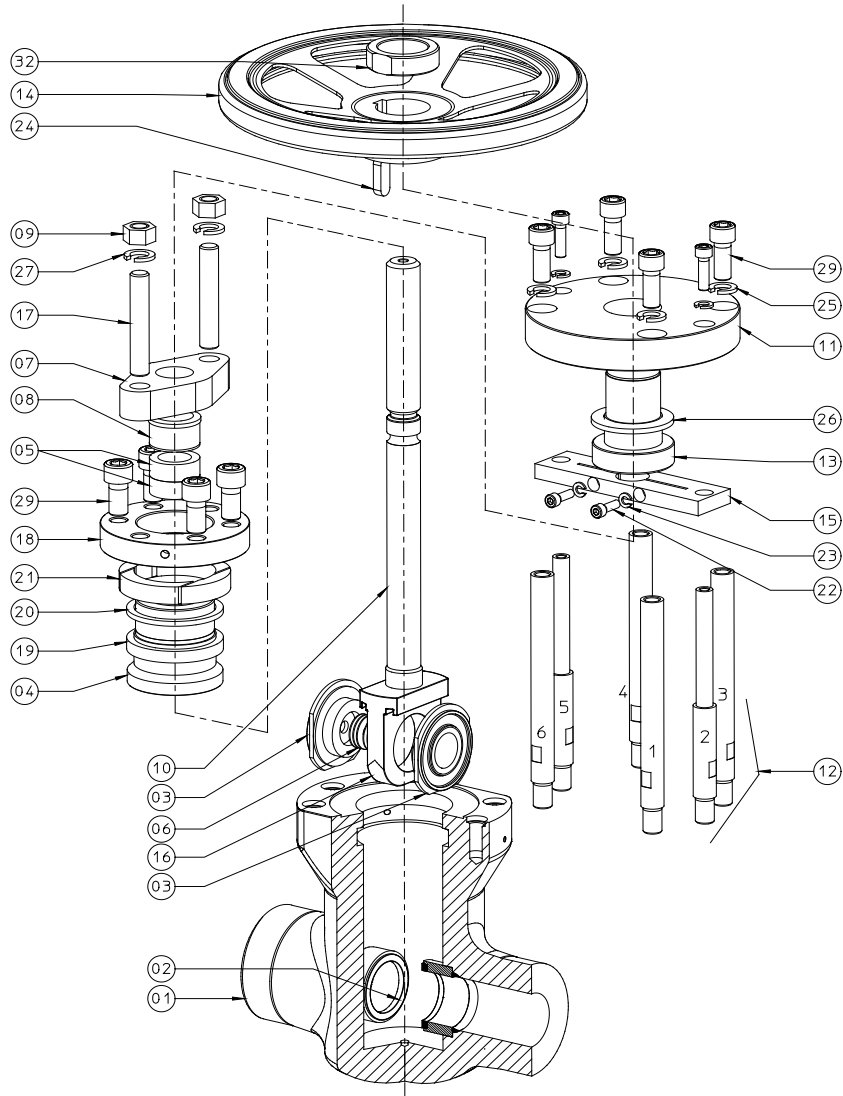

**DISASSEMBLY & ASSEMBLY PARALLEL SLIDE GATE VALVE**

3" - 4" 1500-2500 LBS.

1. Caution, before any attempt is made to disassemble, verify that the valve is isolated from system pressure and secured against accidental pressurisation.
2. For manual operated valves remove hand wheel nut (32), hand wheel (14) and parallel key (24).  
For valves with a Gearbox or Electric Actuator, remove the Actuator, due to unscrewing the bolts (30) from the lower side of the top flange (11).
3. Unscrew hexagon socket screws (29) from the top flange.
4. For manual operated valves screw the yoke sleeve (13) together with the needle bearing (26) from the stem (10).
5. Loosen the bolts (22) from the guiding plate (15) and remove it. Unscrew the stands (12) out of the valve body (01). Unscrew gland bolting/nuts (17-09) and remove them. Remove the gland (07) and gland-bushing (08).
6. Unscrew the bolts (29) from the retaining ring (18) and unscrew the retaining ring from the bonnet (04), while holding up the stem/disc, to secure the bonnet won't fall down and damage the stem.
7. After retaining ring has been removed, lower the stem/disc and bonnet. Remove the segmental ring (21) out of the valve body, by pressing the pins through the bore holes. Now remove the ring (20) and gasket (19), together with the bonnet and stem/disc, by pulling the stem/disc out of the valve body.
8. Dis-assemble the "disc" by turning the first disc-part (03) 90 degrees, so that the lip will come out of the disc holder (16).

INSPECTION FOR RE-ASSEMBLY

1. Thoroughly wipe all parts with solvent and a clean cloth.
2. Examine the following parts for pitting or scratches:
  - A. SEAT (02) - Sealing surface
  - B. STEM - Packing area
  - C. DISC/PART - Sealing surface

3. Place the disc springs (06) (as indicated in Fig.01) into the first disc part. Place this disc part into the disc holder, then place the second part. Place them with one of the three flat machined sides upwards.
4. Place the bonnet over the stem/disc. Pull up the stem/disc a little bit to avoid the bonnet to fall. Place the new gasket in the valve body, with the ring on top of it.
5. Place the segmental ring in the valve body. Make sure that there is no split between two segments placed in front of a disassembly hole. Pull up the stem/disc, with the bonnet through the segmental ring. Screw the retaining ring on the bonnet and tighten it. Screw the bolts into the retaining ring and tighten them.
6. Place packing (05) (first with markings down, second with markings up) over the stem into the bonnet. Place the gland bushing over the stem. Place the gland over the stem and secure them with the gland bolting. Tighten the nuts (to compress the packing). Loosen the nuts, then tighten them carefully again.
7. Screw the stands into the valve body as indicated. Place the guiding plate over the stem on top of stand number 2 and 5. Secure the guiding plate with the hexagon socket screws through the slot in the stem.
8. For manual operated valves screw the yoke sleeve together with the needle bearing on the stem.
9. Place the top flange on top of the stands and secure them with the hexagon socket screws.
10. For manual operated valves turn the yoke sleeve against the top flange, place parallel key, hand wheel and secure it with the hand wheel nut.
11. Pressurise the system and check the gland packing and bonnet.

IMPORTANT

After starting up the system, once the valve has reached its working temperature and pressure, it is recommended to tighten the bolts into the retaining ring to force the bonnet into the gasket for optimum sealing.

12. In case of leaking of the packing tighten the nuts of the gland bolts carefully until the leaking stops. In case of leaking of the bonnet tighten the bolts in the retaining ring.
13. The valve is now ready for use.

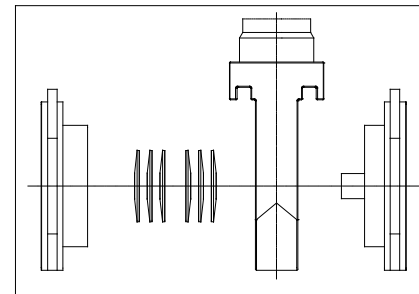
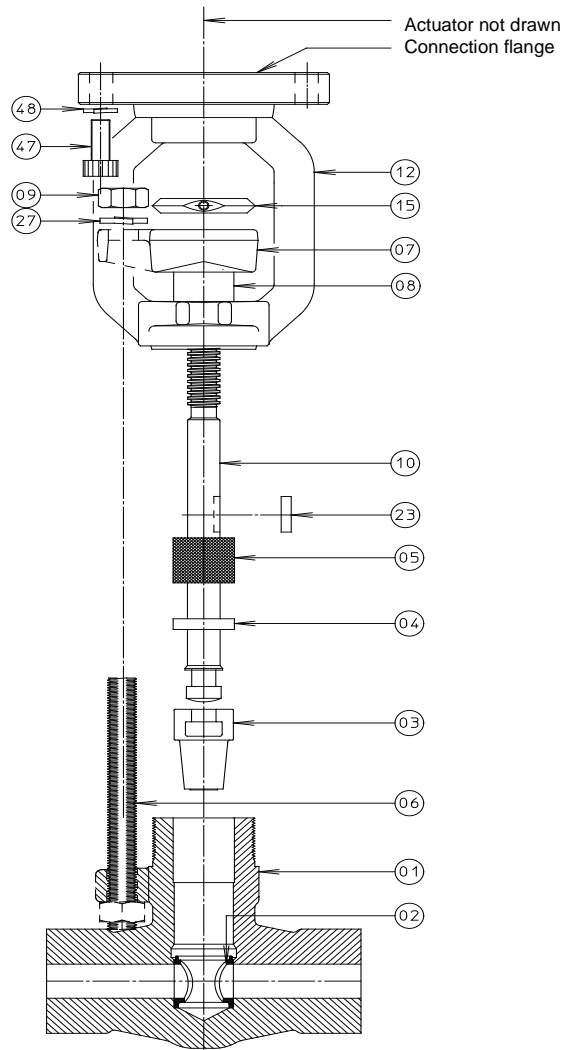

Fig.01

**DISASSEMBLY & ASSEMBLY GATE VALVE**

WITH FLOATING BACKSEAT AND ELECTRIC ACTUATOR (½" - 1")



1. Caution, before any attempt is made to disassemble, verify that the valve is isolated from system pressure and secured against accidental pressurisation.
2. Unscrew the nuts (09) from the gland bolts (09) and remove the gland bolts. Unscrew the hexagon socket screw from the position indicator (15).
3. Open the valve completely. (by means of the manual drive of the actuator) past the fully open to force the packing (05) and the floating backseat (04) out of the valve body (01).
4. Unscrew the bolts (47) which secure the actuator and remove the actuator (unscrewing it from the stem).
5. Loosen the yoke (12) by applying a force in a counterclockwise direction after removing the tack welds which secure the yoke to the valve body.
6. Unscrew the yoke from the valve body and remove the position indicator, the gland flange (07), the gland (08) and the parallel key (23) from the stem (10).
7. Remove the stem and remaining valve internals, from the valve body-body by pulling the stem out of the valve body.
8. Remove the packing and the floating backseat from stem by holding the stem vertically on a bench with the threaded end down and pressing down the floating backseat.

INSPECTION FOR RE-ASSEMBLY

1. Thoroughly wipe all parts with solvent and a clean cloth.
2. Examine the following parts for pitting or scratches:
  - A. SEAT (02) - Sealing surface
  - B. STEM - Packing area
  - C. WEDGE (03) - Sealing surface
3. Grease all threaded parts with molykote HCS, or equivalent.
4. Insert the stem/wedge-assembly into the valve body.
5. Insert the floating backseat (with radius down) into the valve body.
6. Insert the packing into the valve body (with markings down).
7. Put the yoke together with the gland, the gland and position indicator over the stem.
8. Screw the yoke on the valve body.
9. Place the gland flange in the correct position (watch the parallel key) and fix it with the stud bolts.
10. Mount the actuator on top of the connection flange. Adjust the limit switches of the actuator (3/8"-1/2" valve- ±12 mm travel 3/4" - 1" valve - ± 22 mm travel). Switch on the actuator until the valve is in close position. Fix the yoke to the valve body by means of tack welding.
11. Tighten the nuts of the stud bolts. (to compress the packing).
12. Loosen the nuts of the stud bolts.
13. Then carefully tighten the nuts of the stud bolts again.
14. Pressurise the system and check the gland packing.
15. In case of leaking, tighten the nuts of the gland bolts carefully until the leaking stops.

**DISASSEMBLY & ASSEMBLY GATE VALVE**  
WITH FLOATING BACKSEAT AND ELECTRIC ACTUATOR (1 1/4" - 2")

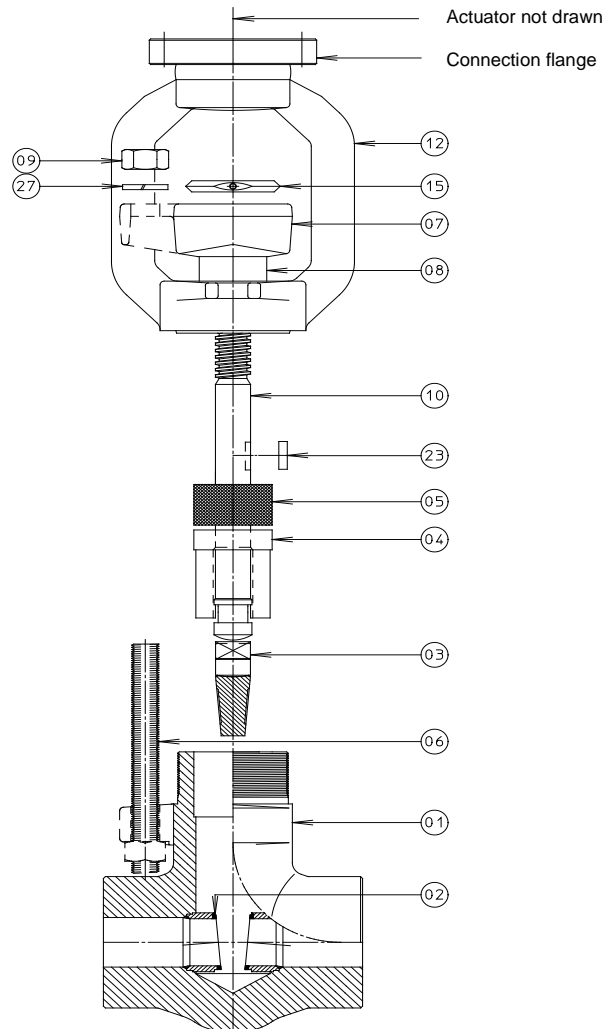

1. Caution, before any attempt is made to disassemble, verify that the valve is isolated from system pressure and secured against accidental pressurisation.
2. Unscrew the nuts (09) from the gland bolts (06) and remove the gland bolts. Unscrew the hexagon socket screw from the position indicator (15).
3. Open the valve completely. (by means of the manual drive of the actuator) past the fully open to force the packing (05) and the floating backseat (04) out of the valve body (01).
4. Unscrew the bolts which secure the actuator and remove the actuator (unscrewing it from the stem).
5. Loosen the yoke (12) by applying a force in a counterclockwise direction after removing the tack welds which secure the yoke to the valve body.
6. Unscrew the yoke from the valve body and remove the position indicator, the gland flange (07), the gland (08) and the parallel key (23) from the stem (10).
7. Remove the stem and remaining valve internals, from the valve body-body by pulling the stem out of the valve body. Caution: be careful with wedge (03).
8. Remove the packing and the floating backseat from stem by holding the stem vertically on a bench with threaded end down and pressing down the floating backseat.

INSPECTION FOR RE-ASSEMBLY

1. Thoroughly wipe all parts with solvent and a clean cloth.
2. Examine the following parts for pitting or scratches:
  - A. SEAT (02) - Sealing surface
  - B. STEM - Packing area
  - C. WEDGE - Sealing surface
3. Grease all threaded parts with molykote HCS, or equivalent.
4. Place the wedge on the stem and place the floating backseat over the stem and the wedge.
5. Insert the packing into the valve body (with markings down).
6. Put the yoke together with the gland, the gland flange and position indicator over the stem.
7. Screw the yoke on the valve body.
8. Place the gland flange in the correct position (watch the parallel key) and fix it with the stud bolts.
9. Mount the actuator on top of the connection flange. Adjust the limit switches of the actuator (1 1/4" - 2" valve- ±42mm travel). Switch on the actuator, until the valve is in close position. Fix the yoke to the valve body by means of tack welding.
10. Tighten the nuts of the stud bolts. (to compress the packing).
11. Loosen the nuts of the stud bolts.
12. Then carefully tighten the nuts of the stud bolts again.
13. Pressurise the system and check the gland packing.
14. In case of leaking, tighten the nuts of the gland bolts carefully until the leaking stops.

**DISASSEMBLY & ASSEMBLY GATE VALVE  
WITH FLOATING BACKSEAT AND PNEUMATIC ACTUATOR**

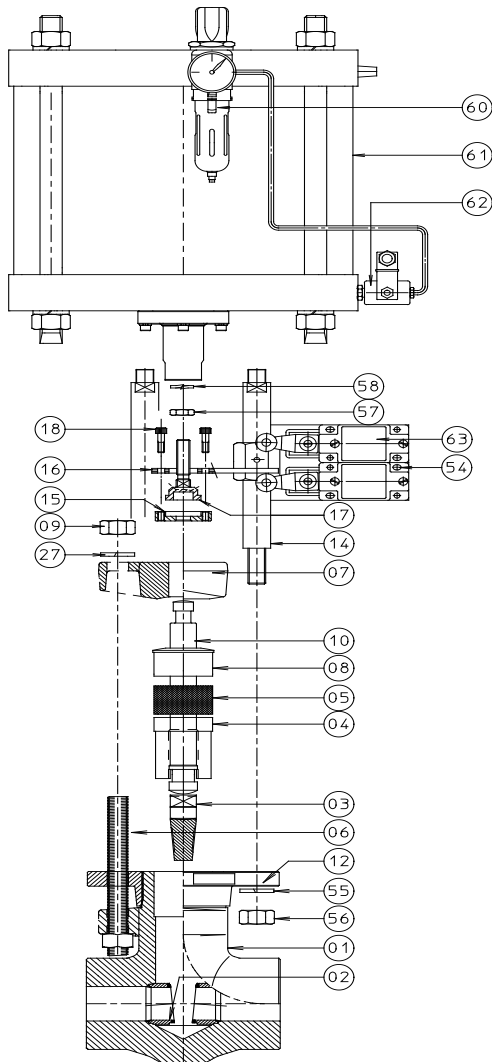

1. Caution, before any attempt is made to disassemble, verify that the valve is isolated from system pressure and secured against accidental pressurisation.
2. Switch on the solenoid valve (62), so the actuator (61) closes the valve.
3. Unscrew the hexagon socket-screws (18) (4x) out of the coupling (15-17).
4. Switch on the solenoid valve, so the actuator opens the valve.
5. Unlock the nut (57) on the threaded end, so you can unscrew the threaded end together with the position indicator (16) out of the air cylinder. Remove the position indicator from the threaded end.
6. Unscrew the nuts (56) (3x) from the spacer columns (14) and remove the air cylinder, spacer columns and limit switches (63) from the screwed flange (12) on the valve body (01).
7. Unscrew the nuts (09) from the stud bolts (06) and remove the stud bolts.
8. Jack the stem (10) together with coupling, the gland flange (07), the gland (08), the packing (05), floating backseat (04) and the wedge (03) out of the valve body.
9. Remove the coupling from the stem. Remove the gland follower from the stem.
10. Remove the gland, packing and the floating backseat from the stem by holding the stem vertically on a bench with the threaded end down and pressing down the floating backseat.

INSPECTION FOR RE-ASSEMBLY

1. Thoroughly wipe all parts with solvent and a clean cloth.
2. Examine the following parts for pitting or scratches:
  - A. SEAT (02) - Sealing surface
  - B. STEM - Packing area
  - C. WEDGE - Sealing surface
3. Grease all threaded parts with molykote HCS, or equivalent.
4. Place the wedge on the stem and place the floating backseat over the stem and the wedge.
5. Insert this assembly into the valve body. Insert the packing into the valve body (with markings down).
6. Place the gland together with the gland flange over the stem. Fix the gland flange with the stud bolts.
7. Tighten the nuts of the stud bolts (to compress the packing).
8. Loosen the nuts of the stud bolts. Then carefully tighten the nuts of the stud bolts again.
9. Place the coupling on the stem. Grease the stem and the threaded end with molykote HCS, or equivalent.
10. Insert the threaded end into the coupling and place the position indicator on top off it. Secure this assembly by screwing in the hexagon socket screws.
11. Switch on the pneumatic actuator in this direction that it opens the valve. Place the actuator, spacer columns and limit switches on the screwed flange on the body and secure them with the nuts and washers (55) (3x).
12. Screw the nut and the washer (58) on the threaded end.
13. Place the pneumatic actuator on the top flange and secure it with the nuts and washers (4x).
14. Screw the threaded end into the pneumatic actuator.
15. Screw the threaded end into the pneumatic actuator until the stem engages the loose backseat. Screw back the threaded end one turn counterclockwise.
16. Switch on the solenoid valve, so the actuator closes the valve.
17. Secure the nut on the threaded end towards the pneumatic actuator.
18. Pressurise the system and check the gland packing. In case of a leaking packing, tighten the nuts from the stud bolts carefully until leaking stops.